



3 PANEL PACK

THE SMART SOLUTION FOR LOFT FLOORS

SMARTPLY MAX OSB3 -
stronger than chipboard

High quality, smooth,
uniform finish

Easily the best choice

FEATURES AND BENEFITS

- Easy and reliable floor fixing
- Easy-to-fit Tongue and Groove panels
- Easy-to-use panel sizes 1220L x 300W x 18mm TG2. Total area 1.1m²
- Easy-to-follow fitting instructions overleaf
- Made from FSC® certified wood.

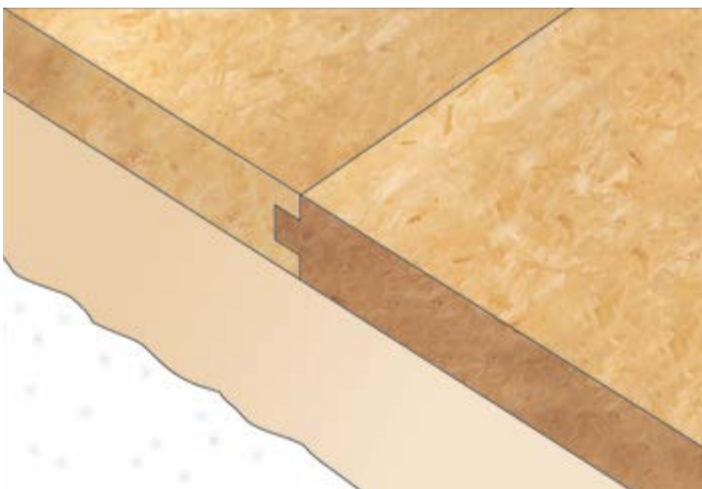

Install panels with expansion gap facing down

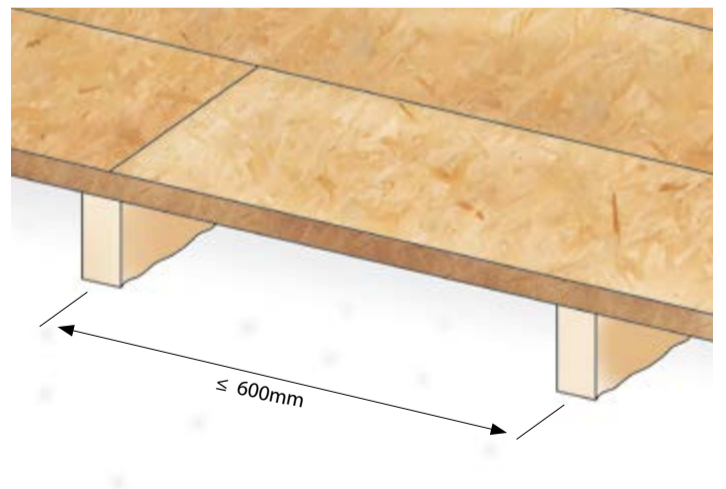

SMARTPLY LOFT Panels are suitable for joist centres up to 600mm in dry loft space

These panels are designed for domestic use with light storage and occasional access only. Do not use in damp conditions. Ensure that the ceiling joists are suitable for load bearing applications. Not suitable for habitable attic rooms

TONGUE & GROOVE OSB LOFT PANELS

GENERAL INFORMATION

Perimeter expansion gap: a minimum 10mm expansion gap should be provided at all rigid upstands. Larger floors may need a wider gap plus intermediate gaps of 2mm per metre to allow for expansion. (Typical small domestic lofts do not require these additional gaps.) (See Fig 1)

SMARTPLY LOFT panels are suitable for joist centres up to 600mm. (See Fig 2)

TYPICAL LAYING INSTRUCTIONS

- These panels are designed for domestic use with light storage and occasional access only. Do not use in damp conditions. Ensure that the ceiling joists are suitable for load bearing applications. Not suitable for habitable attic rooms.
- Ensure no electrical cables or pipes are “pinched” or likely to get damaged when drilling, nailing or screwing
- Where cables cross joists, it will be necessary to reroute them. Do not cut notches in joists for conduit and pipes. If in doubt, always consult a qualified builder (See Fig 3)
- SMARTPLY OSB T&G panels should be laid with their long edges across the supporting joists in a straight line and with the expansion gap of the T&G joint facing down. Short edges should be supported by the joists
- Adjacent lines of panels should be laid so that their cross joints are staggered. For best performance, it is recommended to glue the T&G joints (See Fig 4)
- It is important that edges around the perimeter of the floor and around pipes are continuously supported on joists or noggins. A noggin must support any panel that overhangs a joist. Bridging and noggin supports should be used where required
- Loft panels can be screwed up to 10mm from the edges (See Fig 5)
- Using 50mm screws, panel should be fixed to the joist centres at intervals of no more than 150mm (See Fig 6).

Please dispose of packaging safely and responsibly.

For further information and / or technical advice, please contact your local SMARTPLY Sales Representative or SMARTPLY Technical Support Personnel.
+ 353 (0) 51 832700 or +44 (0) 1322 424900

As we continually update our technical datasheets, please email us at info@mdfosb.com to check that you have the latest version.



Fig 1

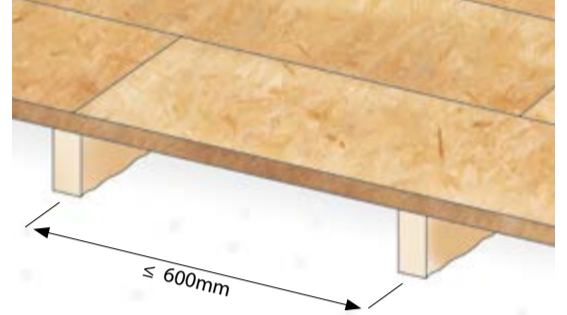

Fig 2

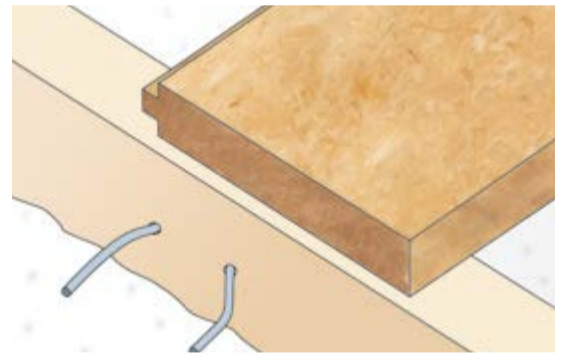

Fig 3



Fig 4

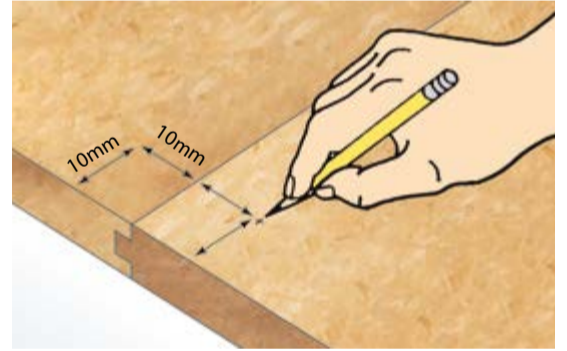

Fig 5

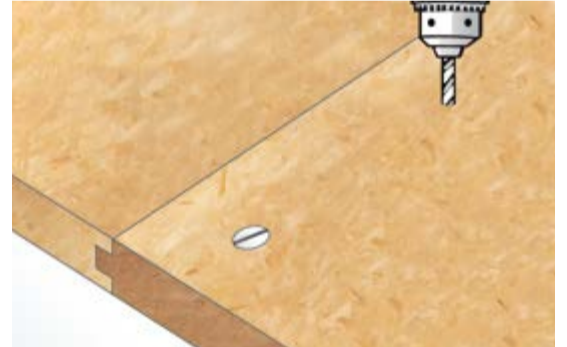

Fig 6

CE	
04 SMARTPLY DOP01Rev4	
0050 EN 13986:2004+A1:2015 Formaldehyde: E1	
OSB/3 Internal use as structural components in humid conditions	
18mm	

